



College of Central Florida
Enterprise Center, Building 42
3003 SW College Rd, Suite 206
Ocala, FL 34474

MARKETING AND OUTREACH COMMITTEE AGENDA

Wednesday, August 17, 2022 – 9:00 a.m.

Zoom Meeting: <https://us02web.zoom.us/j/81831282974>

Phone No: 1-646-558-8656 (EST) Meeting ID: 818 3128 2974

Call to Order		C. Flanagan
Roll Call		C. Schnettler
Approval of Minutes, May 25, 2022	Pages 2 - 3	C. Flanagan

DISCUSSION ITEMS

State Update	R. Skinner
Workforce Issues that are Important to Our Community	R. Skinner
Podcast Topic Discussion for Season 2	D. French

PUBLIC COMMENT

ACTION ITEMS

None

PROJECT UPDATES

Marketing and Outreach Report	Pages 4 - 12	L. Byrnes
-------------------------------	--------------	-----------

MATTERS FROM THE FLOOR

ADJOURNMENT

2022 – 2023 MEETING SCHEDULE

2022 – 2023 MEETING SCHEDULE						
Performance/ Monitoring	Business and Economic Development	Career Center	Marketing/ Outreach	Executive	Full Board	
Tuesday, 9:00 am	Wednesday, 9:00 am	Thursday, 9:30 am	Wednesday, 9:00 am	Wednesday, 9:30 am	Wednesday, 11:30 am	
8/9/2022	8/10/2022	8/18/2022	8/17/2022	8/31/2022	9/7/2022	CF Levy
11/8/2022	11/9/2022	11/17/2022	11/16/2022	11/30/2022	12/7/2022	CF Ocala
2/7/2023	2/8/2023	2/16/2023	2/22/2023	3/1/2023	3/8/2023	CF Lecanto
5/9/2023	5/10/2023	5/18/2023	5/24/2023	5/31/2023	6/7/2023	CF Ocala

OUR VISION STATEMENT

To be known as the number one workforce resource in the state of Florida by providing constructive tools and professional supportive services that are reflected in the quality of our job candidates and meet the needs of the business community.



**CAREERSOURCE CITRUS LEVY MARION
Marketing and Outreach Committee**

MINUTES

DATE: May 25, 2022
PLACE: College of Central Florida, Enterprise Center
TIME: 9:00 a.m.

MEMBERS PRESENT

Albert Jones, Chair
Carl Flanagan
Darlene Goddard
Kathy Judkins

MEMBERS ABSENT

John Murphy
Theresa Flick

OTHER ATTENDEES

Rusty Skinner, CSCLM
Dale French, CSCLM
Cory Weaver, CSCLM

Danielle Veenstra, CSCLM
Cira Schnettler, CSCLM
Nithya Pramekumar, TPMA

CALL TO ORDER

The meeting was called to order by Al Jones, Chair at 9:02 a.m.

ROLL CALL

Cira Schnettler called roll and a quorum was declared present.

APPROVAL OF MINUTES

Darlene Goddard made a motion to approve the minutes from the February 23, 2022 meeting. Kathy Judkins seconded the motion with a correction under the section Workforce Issues that are Important to Our Community. The corrected verbiage: "Kathy Judkins added that her employer, SECO Energy, participates in a youth energy academy hosted by the American Association of Blacks in Energy (AABE). SECO Energy is also looking to engage younger students at the elementary level." Motion carried.

DISCUSSION ITEMS

State Update

Rusty Skinner's updated the committee on the following items:

- DEO recently published a report summarizing the accountability measures for the letter grade system starting in July. The report prompted several concerns from

directors. CLM management will be submitting a response outlining concerns and suggestions for standards in implementation.

Workforce Issues that are Important to Our Community

Al Jones reported that his company, AutoZone, has approved his store for a pilot program hiring 16–17-year-olds in stocking positions.

Kathy Judkins shared that she recently heard a Florida charter high school is working with their local business community to establish a call center work study. SECO Energy will be participating in a local youth energy academy this summer. Eckerd Connects will also be participating. There are seven academies being held around the State this summer.

Draft Strategic Plan

Rusty Skinner explained that after the March board meeting all comments were added to the plan. The plan has been emailed to all board members and will be presented at each committee meeting, then brought before the full board in June for final approval. The plan will be implemented in July 2022. Members can email comments to Rusty Skinner or Dale French. Al Jones commended the hard work on creating the plan and expressed appreciation for the action items for board members.

Talent Pipeline Videos

Rusty Skinner explained that we are developing a list of employers who may want to participate in the talent pipeline video series. Efforts continue to expand marketing to youth in schools. Kathy Judkins added that SECO saw increased positive feedback from students by including short staff testimonials in their marketing videos. Students connected more with staff that were in their peer group.

PUBLIC COMMENT

None

ACTION ITEMS

None

PROJECT UPDATES

Marketing and Outreach Report

Danielle Veenstra highlighted 2021-2022 accomplishments and the 2022-2023 goals. She also presented the landing page for the Lockheed Martin apprenticeship webpage on the CLM website. Carl Flanagan shared an opportunity for a potential funding source and will provide the details to our communications department. He also encouraged committee members to like and share the CLM social media posts.

MATTERS FROM THE FLOOR

None

ADJOURNMENT

There being no further business, the meeting was adjourned at 10:02 a.m.

APPROVED:



OUTREACH COMMITTEE
AUGUST 17, 2022

COMMUNICATIONS UPDATES/HIGHLIGHTS

SHORT FORM VIDEOS

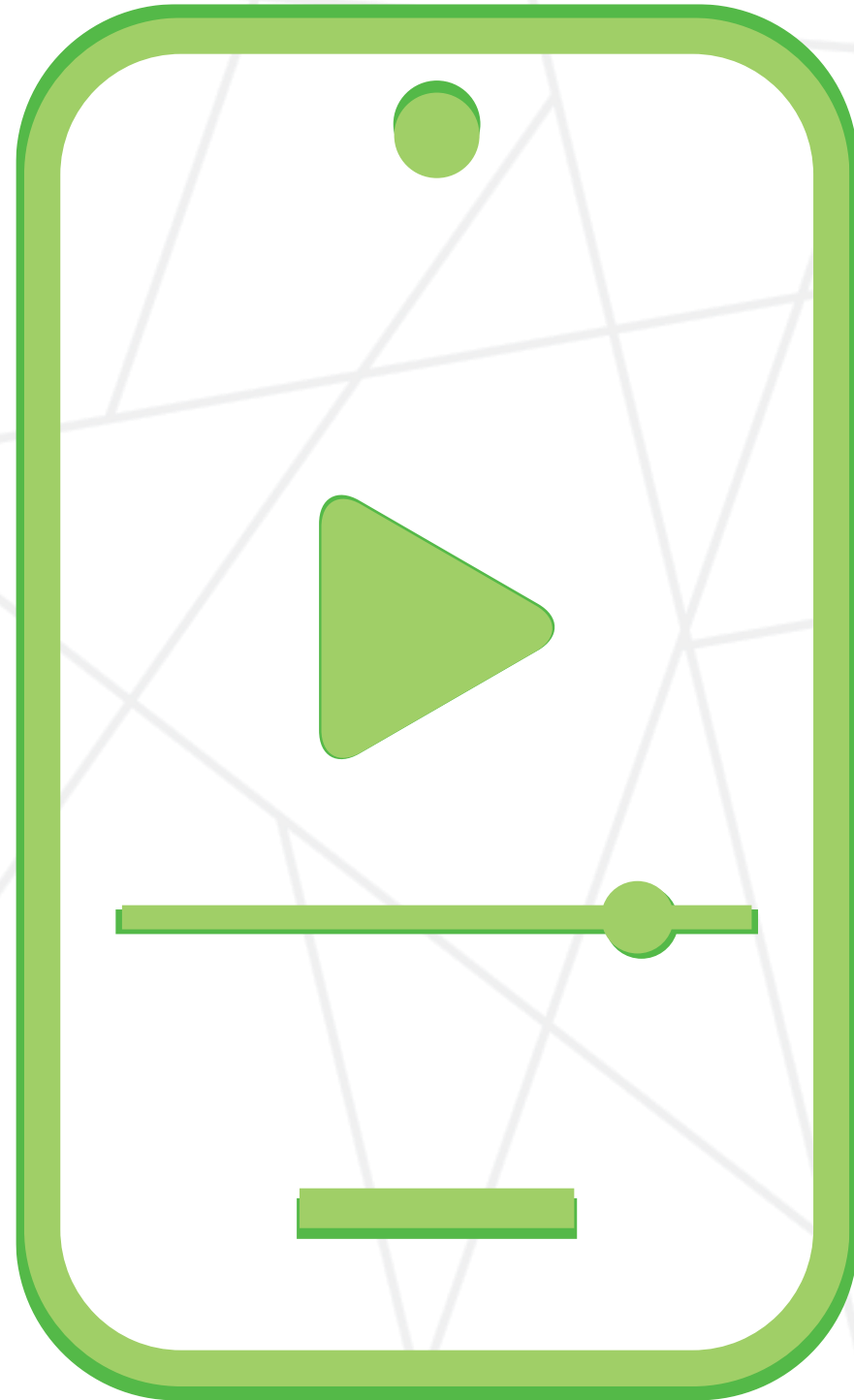

Positions for the
Healthcare and Human
Services Job Fair

Dress for Success at
the Job Fair

Have you seen our most recent TikTok style videos?

With the help of the Business team and some amazing talent, we put our skills together to create fun videos to reach our audiences.

TALENT CENTER WEBSITE

REFRESHING THE FRONT PAGE

The new Talent Center front page will be easy to use, simple, and professional.

We hope to have the new front page up in 2 -3 months. Work has already been done to start that process.

WE CONNECT BUSINESSES WITH PROFESSIONALS

FIND WORK

FIND TALENT

Contact Us or Live Chat

NOT SURE? START HERE.

The Talent Center helps experienced professionals find their next position and more.



Resume Review



Interview Skills



Job Referrals

Start Your Job Search

Job Title

ENTER

Happy Clients, Happy Businesses, and Happy Lives.

"The Talent Center helped me find gainful employment again. Without them I would've been lost."



"The employees I hired from the Talent Center are the best people I've ever had on my team! Amazing!"



"My Resume has never looked better. The Talent Center helped me get my foot in the door. Thank you!"



"The Talent Center helped me find"



Thank you SECO! WE GOT A DRONE

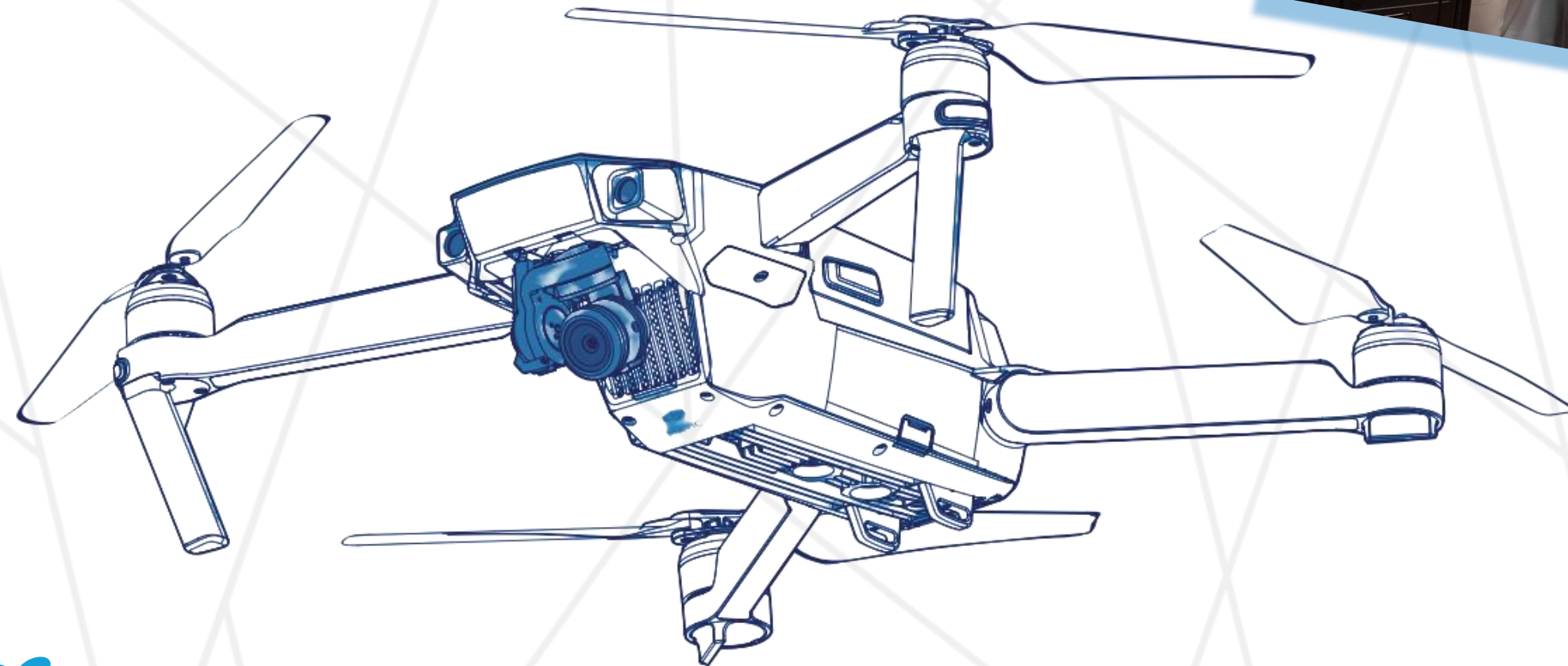

EARNED MEDIA

VIRTUAL HIRING EVENT FOR UF VETERINARY

Sponsored by DeLUCA TOYOTA

wcjb.com to consider its approval for the millage rate for the

MARION CITIZEN

Drop in June jobs rate follows predictable summer pattern

Levy CITIZEN

Serving Levy County Since 1879

Region sees most May employment in 15 years

By Laura Byrnes Director of Communications CareerSource Citrus Levy Marion Special to the Citizen Jun 23, 2022

OCALA — The unemployment rate in the CareerSource Citrus Levy Marion region was 3.1 percent in May. This was 2.0 percentage points lower than the region's year ago rate of 5.1 percent.

Across the three-county region, the labor force in May 2022 was 209,108, up 2,790 for an increase of 1.4 percent over the year. There were 6,436 unemployed residents in the region and 202,672 employed — the most people with jobs in May in the last five years.

Florida News

CareerSource CLM Is Changing Its Focus

LATEST NEWS

- DOJ attempts to revoke search warrant for Donald Trump's home
- William Meister Obituary Union
- Justice Department seeks to revoke search warrant for Trump's home
- Justice Department seeks to revoke search warrant for Trump's home
- East Florida State College | EFSC announces latest Distinguished Teacher Award

Riverland News

Healthcare, human services professionals needed, statist

SPECIAL to the Riverland Jul 20, 2022

Those interested in giving their employment prospects a shot in the arm are encouraged to take part in the 2022 Healthcare and Human Services Job Fair on Tuesday, July 26 from 4-6 p.m. at One Health Center, 1714 SW 17th St., in Ocala.

The free event, sponsored by CareerSource Citrus Levy Marion and VIPcare, features businesses recruiting to fill in-demand positions at area hospitals, doctors' offices, nonprofit organizations, and nursing homes. Positions include Certified Nursing Assistants (CNAs), Child Protective Investigator, Licensed Practical Nurses (LPNs), Registered Nurses (RNs), Patient Care Technicians, Medical Assistants and Medical Lab Technicians, as well as medical office and records, drivers, food service, housekeeping, and more.

Ocala StarBanner | Ocala.com

On-the-job training: CareerSource CLM tweaking its focus to meet ever-changing workforce

By Joe Callahan
Ocala Star-Banner
Published 10:02 p.m. ET June 18, 2022

During the years after the recession hit in 2008, when millions of people lost employment, long lines of job seekers would form early in the morning before a job fair in hopes to nab one of only a handful of positions that employers had to offer.

Today, with the unemployment rate below 3%, dozens and dozens of businesses now head out to job fairs in hopes of enticing candidates with more perks, such as working from home, to change professions.

Despite low unemployment, businesses are hiring. These businesses want to expand. The problem is that there are so many jobs available and workers have many, many choices to make their work life less stressful.

2009: Unemployment rate rises to 12.6%

2022: April unemployment rate was 2.8%, down from March's 3.1%

Where are the workers?: More than half of Florida workers ages 18-64 not working

CITRUS COUNTY CHRONICLE

Summer job fair offers hot new opportunities

SPECIAL TO THE CHRONICLE Jun 6, 2022

If you think summer is the time to sweat out unemployment, think again.

CareerSource Citrus Levy Marion and its affiliate Talent Center, in partnership with the College of Central Florida, will host a Citrus County Job Fair on Tuesday, June 21 – the first official day of summer – featuring a wide range of hot new job opportunities.

The job fair will be from 3:30 to 5 p.m. at CF's Citrus County campus, 3800 S. Lecanto Highway, Lecanto. It is free and open to any job seeker in Citrus, Levy and Marion counties.

the Ocala Gazette

Healthcare and human services professionals needed now

Job fair features wide array of opportunities in medical and nonprofit fields.

Home » Community

Posted July 20, 2022 | By Ocala Gazette Staff

The 2022 Healthcare and Human Services Job Fair will take place on Tuesday, July 26, from 4-6 p.m. at One Health Center, 1714 S.W. 17th St. in Ocala, according to a July 18 press release.

Sponsored by CareerSource Citrus Levy Marion (CLM) and VIPcare, the free event features businesses recruiting to fill in-demand positions at area hospitals, doctors' offices, nonprofit organizations and nursing homes.

"Healthcare is one of those industries in our region that continues to be in very high demand," said Melissa Saco, CareerSource CLM business development manager. "To help meet that need, this job fair features an abundance of immediate opportunities from entry level to registered and licensed nurses."

Positions include certified nursing assistants (CNAs), child protective investigator, licensed practical nurses (LPNs), registered nurses (RNs), patient care technicians, medical assistants and medical lab technicians, as well as medical office and records, drivers, food service, housekeeping and more.

To date, the following businesses are scheduled to take part: Absolute Health Internal Medicine and Pediatrics; Bridgewater Park Health and Rehabilitation; Brookside Chamber Pinecreek Chatham Glen Healthcare & Rehabilitation; Empath Home Health; Evergreen Private Care; Florida Department of Children and Families; HCA Florida Ocala Health; Heart of Florida Health Care; Highpoint at Stonecrest; Hospice of Marion County; Maxim Healthcare Services; Quad Nurse, LLC; SMA Healthcare; Staff America and Team Select Home Care.

Additionally, education partners Taylor College and the College of Central Florida will be on hand.

Candidates are asked to register prior to the event. Those planning to attend should bring printed copies of their resume, dress professionally and be prepared for an on-the-spot job interview. While masks are not required, participants should feel comfortable in wearing appropriate face covering if they wish.

CAREERSOURCE JOB FAIR

Sponsored by BAGEN

LOTTERY 07/25/22

POWERBALL 25 37 38 39 65 05 2 POWERPLAY

6:37 72°

Ocala-News.com

CareerSource CLM hosting online hiring event for UF Veterinary Hospitals in Marion and Alachua counties

Job seekers with a passion for animals are invited to attend a virtual hiring event for the University of Florida Veterinary Hospitals in Marion and Alachua counties on Tuesday, August 2, from 11 a.m. to 1 p.m.

The free online hiring event is being held by CareerSource Citrus Levy Marion and its affiliate Talent Center at the College of Central Florida in partnership with CareerSource North Central Florida.

Andrea Abrams, manager of the Talent Center, said, "Because UF Veterinary Hospitals and their

LIVE BUSINESS SHOWCASE



WCLM

WE ARE LIVE TOMORROW

10 AM: Brookdale Senior Living

10:30 AM: UF's College of Veterinary Medicine

CareerSource
CITRUS | LEVY | MARION

A graphic featuring a large blue microphone icon. The top of the microphone has 'WCLM' written on it, and the bottom has 'BUSINESS SHOWCASE'. To the right of the microphone, the text 'WE ARE LIVE TOMORROW' is displayed in large, bold letters. Below this, the schedule for the event is listed: '10 AM: Brookdale Senior Living' and '10:30 AM: UF's College of Veterinary Medicine'. At the bottom right is the CareerSource logo, which consists of three colored squares (orange, green, blue) and the text 'CareerSource CITRUS | LEVY | MARION'.

THE BIZ SPOT: SEASON 2



Season 1 Episode List

Ep. 1: The Benefits and Consequences of Florida's New Minimum Wage

Ep. 2: The Curious Case of Disappearing Talent

Ep. 3: Talent Pools

Ep. 4: A Sneak Peek into the Art of HR Conference

Ep. 5: The Hazy Issue of Marijuana in the Workplace

Ep. 6: Digging into Labor Force Participation Rates with Kevin Sheilley

Ep. 7: Getting back into the Workforce after Retirement

Ep. 8: Special Episode Featuring Mid-FL Regional Manufacturers Association

OTHER HIGHLIGHTS



SPEAKERS BUREAU

Material updates: Elevator pitches, Mission and Vision one-sheeter, and PowerPoint presentations



TALENT PIPELINE VIDEOS

Latest round of business videos are (nearly) in the can!



IN THE WORKS / UPCOMING

Summit, MC General Job Fair, Citrus County Youth Career Expo (virtual), Marion County Youth Career Expo, Paychecks for Patriots



LIKE/SHARE/FOLLOW

Help us spread our message to new candidates. The more interaction on our page the more AI shares it with new people.



QUESTIONS?

